

AVINENT<sup>®</sup>

Implant System

**TECHNICAL  
INFORMATION**

## CONTENTS

Schematic of the AVINENT system with external hex **4**

Schematic of the AVINENT system with internal hex **6**

**1** Implants **8**

**2** Healing abutments **12**

**3** Temporary abutments **14**

**4** Transepithelial abutments **16**

**5** Impression copings open tray **18**

**6** Impression copings closed tray **20**

**7** Implant replicas **22**

**8** Overdentures **25**

**9** Cemented restorations **31**

**10** Screw-retained restorations **35**



SURGICAL PHASE

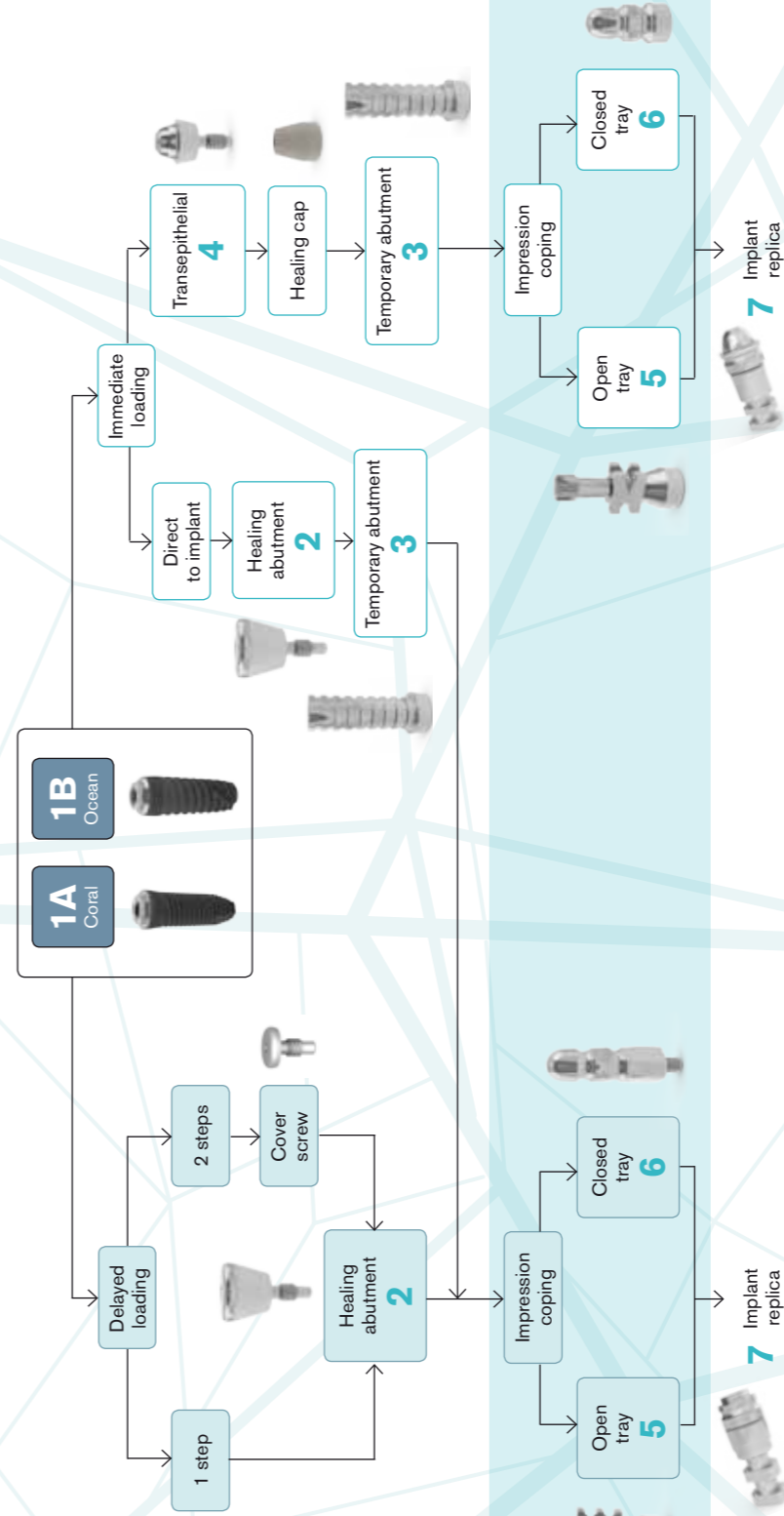

IMPRESSION  
COPING PHASE

PROSTHETIC PHASE

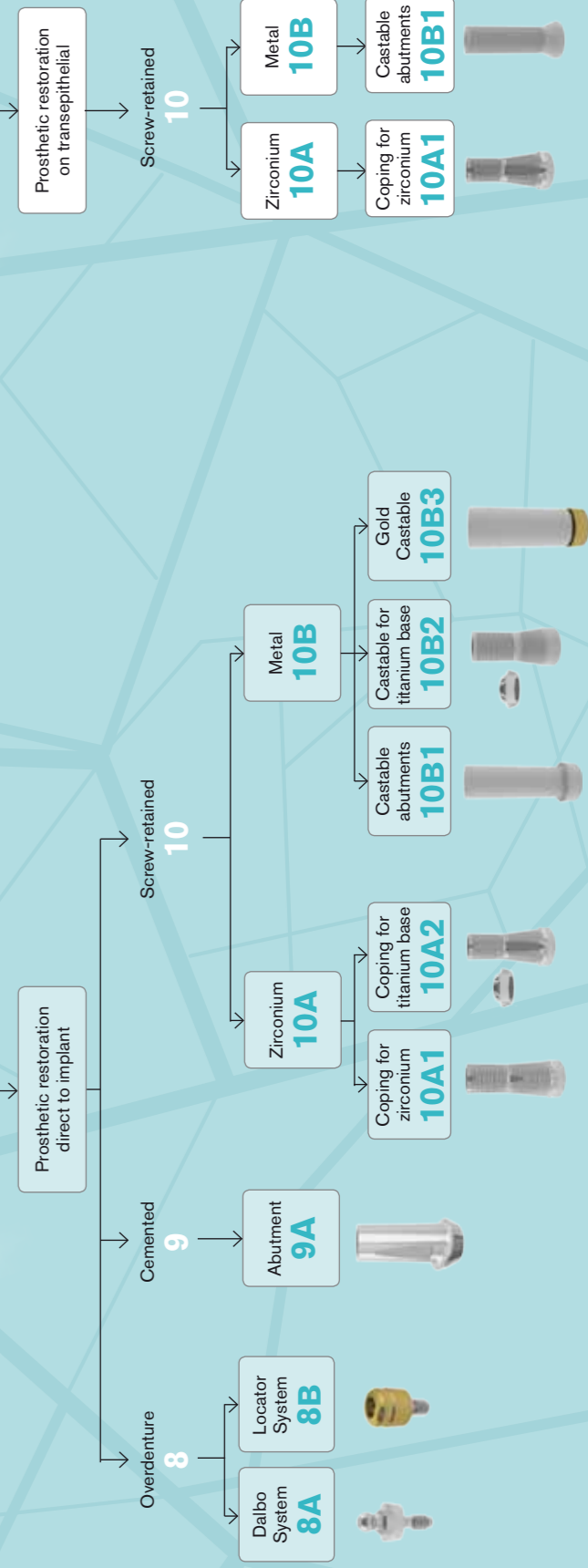



SURGICAL PHASE

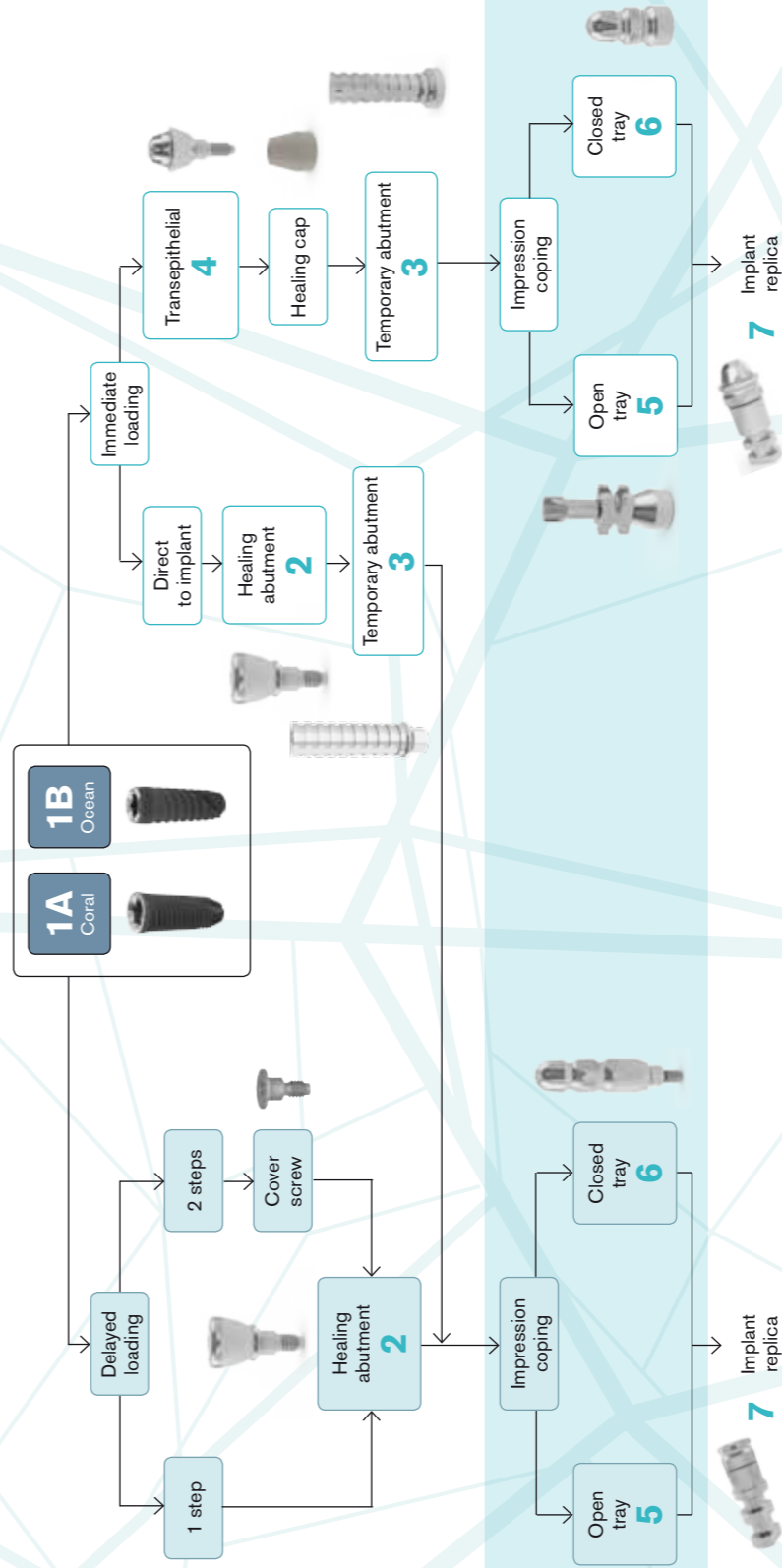

IMPRESSION  
COPING PHASE

PROSTHETIC PHASE

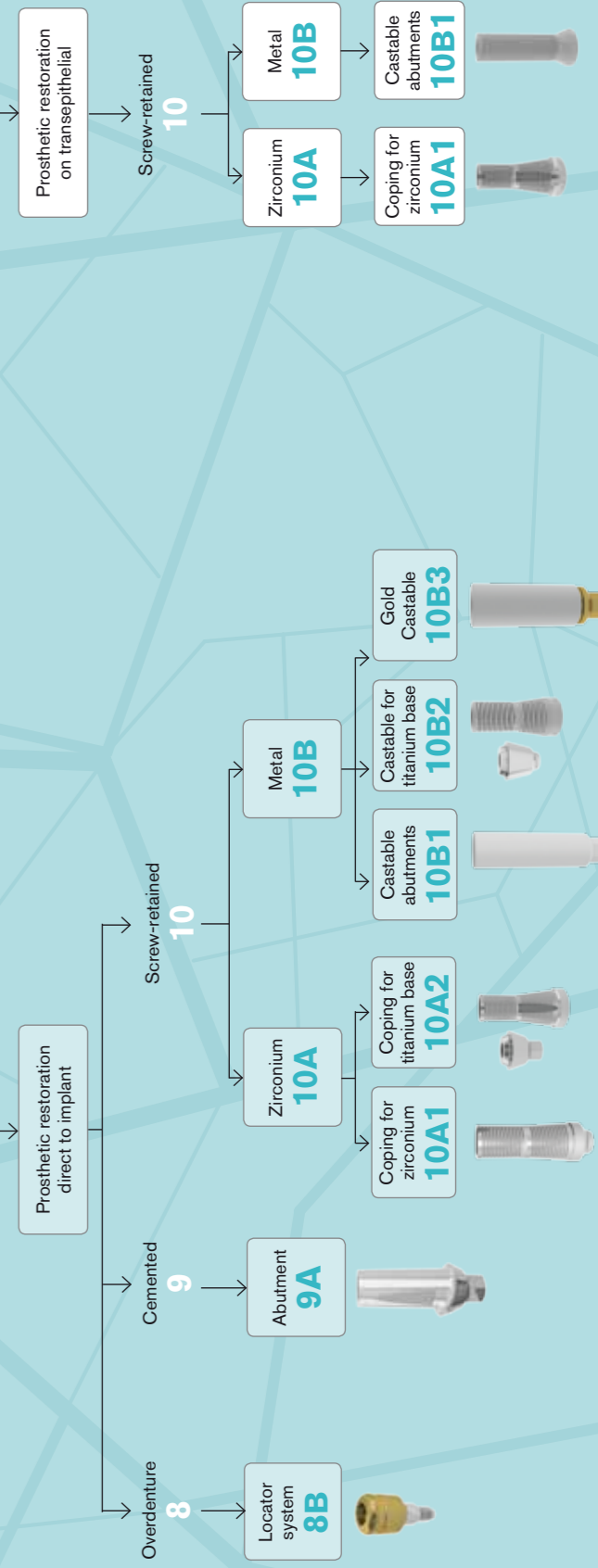

# 1A CORAL BIOMIMETIC Implant

AVINENT®  
Implant System

## Description



The advanced design of the BIOMIMETIC CORAL implant guarantees success in any placement protocol.  
The implant has an outstanding penetrative ability thanks to its triple thread that is uniform along its entire body.  
The design of the spirals reduces the angles, decreases surface tension and enhances the wettability of the implant.  
The micro-thread in the cortical zone enables loads to be optimally distributed and reduces the stresses in this area.  
The latest-generation Biomimetic Advanced Surface treatment increases the implant-bone contact area and encourages osseointegration.

## Technical specifications

Connections
Materials
Geometry

platforms			
HE	3.5	4.1	5.1
HI	3.5	4.1	

Ti6Al4V – Grade V

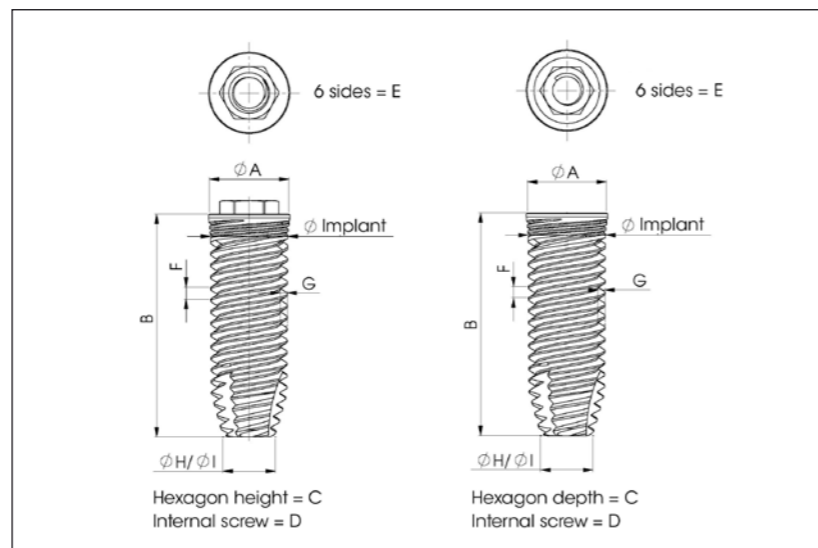

	HE									HI									
	A	B	C	D	E	F	G	H	I	A	B	C	D	E	F	G	H	I	
Ø 3.3	3.5	3.5	A/C	0.7	M-1.8 x 0.35	2.4	1.50	0.30	1.9	1.9	3.5	A/C	2	M-1.8 x 0.35	2.42	1.50	0.30	1.9	1.9
	4.1	4.1	A/C	0.7	M-2.0 x 0.4	2.7	1.50	0.30	1.9	1.9	4.1	A/C	2	M-1.8 x 0.35	2.42	1.50	0.30	1.9	1.9
Ø 3.8	4.1	4.1	A/C	0.7	M-2.0 x 0.4	2.7	1.80	0.36	2.4	2.6	4.1	A/C	2	M-1.8 x 0.35	2.42	1.80	0.36	2.4	2.6
Ø 4.0	4.1	4.1	A/C	0.7	M-2.0 x 0.4	2.7	1.80	0.36	2.6	2.8	4.1	A/C	2	M-1.8 x 0.35	2.42	1.80	0.36	2.6	2.8
Ø 4.2	4.1	4.1	A/C	0.7	M-2.0 x 0.4	2.7	1.80	0.36	2.8	3.0	4.1	A/C	2	M-1.8 x 0.35	2.42	1.80	0.36	2.8	3.0
Ø 4.8	4.1	4.1	A/C	0.7	M-2.0 x 0.4	2.7	2.40	0.48	3.4	3.1	4.1	A/C	2	M-1.8 x 0.35	2.42	2.40	0.48	3.4	3.1
	5.1	5.1	A/C	0.7	M-2.5 x 0.45	3.4	2.40	0.50	3.4	3.1									

A/C = According to catalogue  
H = Ø of the tip of all the implants except those that measure 7 mm and 8.5 mm in length  
I = Ø of the tip of the 7 mm and 8.5 mm long implants

## Usage techniques

- Manual placement using a torque wrench or mechanically with contra-angle.
- Maximum recommended torque for inserting the implant: 45-50 Ncm.
- The drilling sequence for inserting the implant recommended by AVINENT should be used (see Coral catalogue).
- The same surgical box serves for both external hex (HE) and internal hex (HI).
- Use the 0.35-inch screwdriver for the HE cover screw and the 0.48-inch screwdriver for the HI cover screw.

## Notes

- Internal and external hex available.
- Biomimetic Advanced Surface (BAS) treatment.
- Continuous thread.
- Cover screw included in the blister pack.

## References

Platform	Diameter	HE		HI	
3.5	Ø 3.3	Implant HE 3.3 x 10 mm (3.5)	0123	Implant HI 3.3 x 10 mm (3.5)	0385
		Implant HE 3.3 x 11.5 mm (3.5)	0124	Implant HI 3.3 x 11.5 mm (3.5)	0386
		Implant HE 3.3 x 13 mm (3.5)	0125	Implant HI 3.3 x 13 mm (3.5)	0387
				Implant HI 3.3 x 15 mm (3.5)	0388
4.1	Ø 3.3	Implant HE 3.3 x 10 mm (4.1)	0184	Implant HI 3.3 x 10 mm (4.1)	0408
		Implant HE 3.3 x 11.5 mm (4.1)	0185	Implant HI 3.3 x 11.5 mm (4.1)	0409
		Implant HE 3.3 x 13 mm (4.1)	0186	Implant HI 3.3 x 13 mm (4.1)	0410
		Implant HE 3.3 x 15 mm (4.1)	0187	Implant HI 3.3 x 15 mm (4.1)	0411
4.1	Ø 3.8	Implant HE 3.8 x 7 mm (4.1)	0836	Implant HI 3.8 x 7 mm (4.1)	0841
		Implant HE 3.8 x 8.5 mm (4.1)	0122	Implant HI 3.8 x 8.5 mm (4.1)	0389
		Implant HE 3.8 x 10 mm (4.1)	0121	Implant HI 3.8 x 10 mm (4.1)	0390
		Implant HE 3.8 x 11.5 mm (4.1)	0126	Implant HI 3.8 x 11.5 mm (4.1)	0391
		Implant HE 3.8 x 13 mm (4.1)	0127	Implant HI 3.8 x 13 mm (4.1)	0392
		Implant HE 3.8 x 15 mm (4.1)	0128	Implant HI 3.8 x 15 mm (4.1)	0393
4.1	Ø 4.0	Implant HE 4.0 x 7 mm (4.1)	0837	Implant HI 4.0 x 7 mm (4.1)	0842
		Implant HE 4.0 x 8.5 mm (4.1)	0129	Implant HI 4.0 x 8.5 mm (4.1)	0394
		Implant HE 4.0 x 10 mm (4.1)	0130	Implant HI 4.0 x 10 mm (4.1)	0395
		Implant HE 4.0 x 11.5 mm (4.1)	0001	Implant HI 4.0 x 11.5 mm (4.1)	0396
		Implant HE 4.0 x 13 mm (4.1)	0131	Implant HI 4.0 x 13 mm (4.1)	0397
		Implant HE 4.0 x 15 mm (4.1)	0132	Implant HI 4.0 x 15 mm (4.1)	0398
4.1	Ø 4.2	Implant HE 4.2 x 7 mm (4.1)	0838	Implant HI 4.2 x 7 mm (4.1)	0843
		Implant HE 4.2 x 8.5 mm (4.1)	0133	Implant HI 4.2 x 8.5 mm (4.1)	0399
		Implant HE 4.2 x 10 mm (4.1)	0134	Implant HI 4.2 x 10 mm (4.1)	0400
		Implant HE 4.2 x 11.5 mm (4.1)	0135	Implant HI 4.2 x 11.5 mm (4.1)	0401
		Implant HE 4.2 x 13 mm (4.1)	0136	Implant HI 4.2 x 13 mm (4.1)	0402
		Implant HE 4.2 x 15 mm (4.1)	0137	Implant HI 4.2 x 15 mm (4.1)	0403
4.1	Ø 4.8	Implant HE 4.8 x 7 mm (4.1)	0840	Implant HI 4.8 x 7 mm (4.1)	0844
		Implant HE 4.8 x 8.5 mm (4.1)	0560	Implant HI 4.8 x 8.5 mm (4.1)	0404
		Implant HE 4.8 x 10 mm (4.1)	0561	Implant HI 4.8 x 10 mm (4.1)	0405
		Implant HE 4.8 x 11.5 mm (4.1)	0562	Implant HI 4.8 x 11.5 mm (4.1)	0406
		Implant HE 4.8 x 13 mm (4.1)	0563	Implant HI 4.8 x 13 mm (4.1)	0407
5.1	Ø 4.8	Implant HE 4.8 x 7 mm (5.1)	0839		
		Implant HE 4.8 x 8.5 mm (5.1)	0138		
		Implant HE 4.8 x 10 mm (5.1)	0139		
		Implant HE 4.8 x 11.5 mm (5.1)	0140		
		Implant HE 4.8 x 13 mm (5.1)	0141		

## Description

The shape of the BIOMIMETIC OCEAN implant guarantees excellent aesthetic results at tissue level.

It features innovative concepts such as platform switching at positive angle with polished surface, micro-spiral neck, progressive and asymmetrical double thread and apical end with radial tip to eliminate insult to anatomical structures.

The latest-generation Biomimetic Advanced Surface treatment increases the implant-bone contact area and encourages osseointegration.



## Technical specifications

### Connections

	platforms	
HE	3.5	4.1
HI	3.5	4.1



### Materials

Ti6Al4V – Grade V

### Geometry

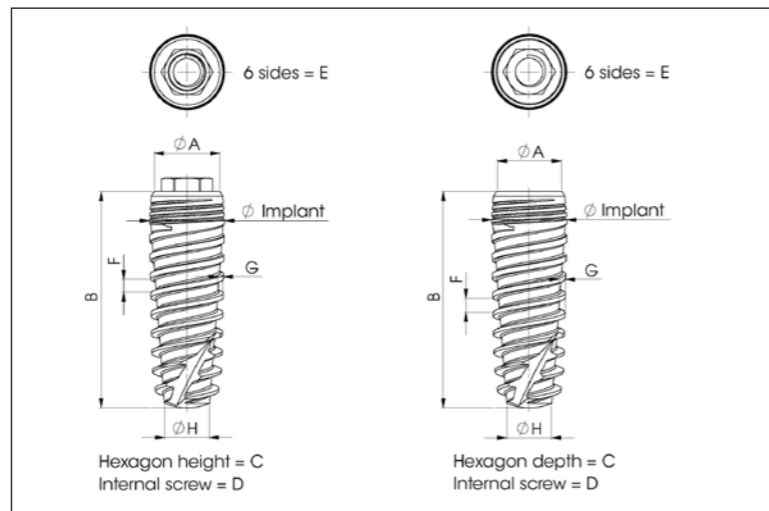

	HE									HI							
	A	B	C	D	E	F	G	H		A	B	C	D	E	F	G	H
Ø 3.5	3.5	3.5	A/C	0.7	M-1.8 x 0.35	2.4	1	0.50	2.20	3.5	A/C	2	M-1.8 x 0.35	2.42	1	0.50	2.20
	4.1										A/C	2	M-1.8 x 0.35	2.42	1	0.50	2.20
Ø 4.0	3.5	3.5	A/C	0.7	M-1.8 x 0.35	2.4	1	0.50	2.40	3.5	A/C	2	M-1.8 x 0.35	2.42	1	0.50	2.40
	4.1										A/C	2	M-1.8 x 0.35	2.42	1	0.50	2.40
Ø 4.5	3.5									4.1	A/C	2	M-1.8 x 0.35	2.42	1	0.50	3.0
	4.1	4.1	A/C	0.7	M-2.0 x 0.4	2.7	1	0.50	3.0		A/C	2	M-1.8 x 0.35	2.42	1	0.50	3.0
Ø 5.0	3.5									4.1	A/C	2	M-1.8 x 0.35	2.42	1	0.50	3.40
	4.1	4.1	A/C	0.7	M-2.0 x 0.4	2.7	1	0.50	3.40		A/C	2	M-1.8 x 0.35	2.42	1	0.50	3.40

A/C = According to catalogue

## Usage techniques

- Manual placement using a torque wrench or mechanically with contra-angle.
- Maximum recommended torque for inserting the implant: 45-50 Ncm.
- The drilling sequence for inserting the implant recommended by AVINENT should be used (see Ocean catalogue).
- The same surgical box serves for both external hex (HE) and internal hex (HI).
- Use the 0.48-inch screwdriver for both the HE and HI cover screw.

## Notes

- Internal and external hex available.
- Biomimetic Advanced Surface (BAS) treatment.
- Continuous thread.
- Cover screw included in the blister pack.
- Transporting tool with temporary abutment function.

## References

Platform	Diameter	HE		HI	
		Implant	Part No.	Implant	Part No.
3.5	Ø 3.5	Implant HE 3.5 x 10 mm (3.5)	1558	Implant HI 3.5 x 10 mm (3.5)	1579
		Implant HE 3.5 x 11.5 mm (3.5)	1559	Implant HI 3.5 x 11.5 mm (3.5)	1580
		Implant HE 3.5 x 13 mm (3.5)	1560	Implant HI 3.5 x 13 mm (3.5)	1581
		Implant HE 3.5 x 15 mm (3.5)	1561	Implant HI 3.5 x 15 mm (3.5)	1582
3.5	Ø 4.0	Implant HE 4.0 x 7 mm (3.5)	1562	Implant HI 4.0 x 7 mm (3.5)	1583
		Implant HE 4.0 x 8.5 mm (3.5)	1563	Implant HI 4.0 x 8.5 mm (3.5)	1584
		Implant HE 4.0 x 10 mm (3.5)	1564	Implant HI 4.0 x 10 mm (3.5)	1585
		Implant HE 4.0 x 11.5 mm (3.5)	1565	Implant HI 4.0 x 11.5 mm (3.5)	1586
		Implant HE 4.0 x 13 mm (3.5)	1566	Implant HI 4.0 x 13 mm (3.5)	1587
4.1	Ø 4.5	Implant HE 4.5 x 7 mm (4.1)	1568	Implant HI 4.5 x 7 mm (4.1)	1589
		Implant HE 4.5 x 8.5 mm (4.1)	1569	Implant HI 4.5 x 8.5 mm (4.1)	1590
		Implant HE 4.5 x 10 mm (4.1)	1570	Implant HI 4.5 x 10 mm (4.1)	1591
		Implant HE 4.5 x 11.5 mm (4.1)	1571	Implant HI 4.5 x 11.5 mm (4.1)	1592
4.1	Ø 5.0	Implant HE 4.5 x 13 mm (4.1)	1572	Implant HI 4.5 x 13 mm (4.1)	1593
		Implant HE 4.5 x 15 mm (4.1)	1573	Implant HI 4.5 x 15 mm (4.1)	1594
		Implant HE 5.0 x 7 mm (4.1)	1574	Implant HI 5.0 x 7 mm (4.1)	1595
		Implant HE 5.0 x 8.5 mm (4.1)	1575	Implant HI 5.0 x 8.5 mm (4.1)	1596
4.1	Ø 5.0	Implant HE 5.0 x 10 mm (4.1)	1576	Implant HI 5.0 x 10 mm (4.1)	1597
		Implant HE 5.0 x 11.5 mm (4.1)	1577	Implant HI 5.0 x 11.5 mm (4.1)	1598
		Implant HE 5.0 x 13 mm (4.1)	1578	Implant HI 5.0 x 13 mm (4.1)	1599

# 2 Healing abutments

**Description** These titanium abutments make guided healing of the soft tissue possible (in single-step surgical operations).  
AVINENT supplies three types of abutment: standard, anatomic and aesthetic.



**Technical specifications**

**Connections**

	platforms		
HE	3.5	4.1	5.1
HI	3.5	4.1	

**Materials**

Ti6Al4V – Grade V

**Geometry**

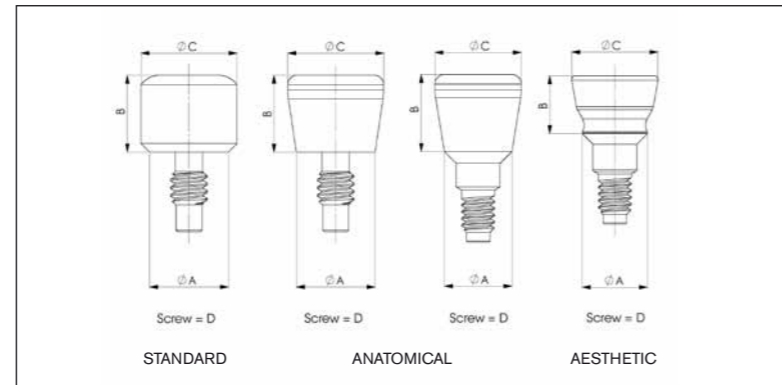

		HE				HI			
		A	B	C	D	A	B	C	D
Healing abutment	3.5	3.5	A/C	4 5	M 1.8 x 0.35				
	4.1	4.1	A/C	5	M 2.0 x 0.40				
	5.1	5.1	A/C	6	M 2.5 x 0.45				
Anatomical healing abutment	3.5	3.5	A/C	5	M 1.8 x 0.35	3.52	A/C	4.5	M 1.8 x 0.35
	4.1	4.1	A/C	5	M 2.0 x 0.40	3.52	A/C	5.5	M 1.8 x 0.35
	5.1	5.1	A/C	6	M 2.5 x 0.45				
Aesthetic healing abutment	3.5					3.52	A/C	4.5	M 1.8 x 0.35
	4.1					3.52	A/C	4.5	M 1.8 x 0.35
	5.1								

A/C = According to catalogue

- Usage techniques**
- Use the appropriate abutments to suit the implant hex and platform.
  - Manually-applied torque should be used.
  - Use the 0.48-inch screwdriver (see catalogue for various options).
  - The product should be sterilized prior to use, as indicated on the label.

- Notes**
- Tremendous versatility of shapes and heights.
  - The concept of platform switching is introduced in the internal hex.
  - The height of the abutment is identified by the laser marking on the upper face.

**References**

Platform	HE	
3.5	Healing abutment HE 4 x 3 mm	0030
	Healing abutment HE 4 x 4 mm	0031
	Healing abutment HE 4 x 5 mm	0032
	Healing abutment HE 5 x 3 mm	0033
	Healing abutment HE 5 x 4 mm	0034
	Healing abutment HE 5 x 5 mm	0035
4.1	Healing abutment HE 5 x 3 mm	0036
	Healing abutment HE 5 x 4 mm	0037
	Healing abutment HE 5 x 5 mm	0003
	Healing abutment HE 5 x 7 mm	0038
5.1	Healing abutment HE 6 x 3 mm	0039
	Healing abutment HE 6 x 4 mm	0040
	Healing abutment HE 6 x 5 mm	0041
3.5 4.1	Anatomical healing abutment HE 5 x 3 mm	0171
	Anatomical healing abutment HE 5 x 4 mm	0172
	Anatomical healing abutment HE 5 x 5 mm	0173
	Anatomical healing abutment HE 5 x 3 mm	0174
	Anatomical healing abutment HE 5 x 4 mm	0175
	Anatomical healing abutment HE 5 x 5 mm	0176
	Anatomical healing abutment HE 5 x 7 mm	0177
	Anatomical healing abutment HE 6 x 3 mm	0178
	Anatomical healing abutment HE 6 x 4 mm	0179
	Anatomical healing abutment HE 6 x 5 mm	0180
	Anatomical healing abutment HI 4.5 x 2 mm	0465
	Anatomical healing abutment HI 4.5 x 3 mm	0466
Anatomical healing abutment HI 4.5 x 4 mm	0467	
Anatomical healing abutment HI 4.5 x 5 mm	0468	
Anatomical healing abutment HI 4.5 x 7 mm	0469	
Anatomical healing abutment HI 5.5 x 3 mm	0471	
Anatomical healing abutment HI 5.5 x 4 mm	0472	
Anatomical healing abutment HI 5.5 x 5 mm	0473	
Anatomical healing abutment HI 5.5 x 7 mm	0474	
Aesthetic healing abutment HI 4.5 x 2 mm	0607	
Aesthetic healing abutment HI 4.5 x 3 mm	0608	
Aesthetic healing abutment HI 4.5 x 4 mm	0609	
Aesthetic healing abutment HI 4.5 x 5 mm	0610	
Aesthetic healing abutment HI 4.5 x 6 mm	0611	
Aesthetic healing abutment HI 4.5 x 7 mm	0612	

# 3 Temporary abutments

**Description** Temporary titanium or PEEK abutments are used to fabricate temporary restorations. They serve as supporting elements by being screwed to the implant or the transepithelial abutment.



## Technical specifications

Connections	platforms		
	HE	3.5	4.1
HI	3.5	4.1	
Transepithelial			

Materials	Ti6Al4V – Grade V	Peek
-----------	-------------------	------

HE

HI

Transepithelial

		HE				HI				Transepithelial		
		A	B	C	D	A	B	C	D	A	B	C
Titanium and Peek	3.5	3.5	12	1.6	4	3.52	12	0.5	3.9			
	4.1	4.1	12	1.6	4.5	3.52	12	0.5	3.9			
	5.1	5.1	12	1.6	5.4							
										4.8	12	1

**Usage techniques**

- Use the appropriate temporary abutment and screw to suit the implant hex and platform.
- The hexagonal temporary abutment is indicated for single restorations and the cylindrical temporary abutment is indicated for multiple restorations.
- The titanium temporary abutments should be screwed to 35 Ncm and the PEEK temporary abutments should be screwed by hand using the appropriate permanent screw, as indicated in the catalogue.
- Use the 0.48-inch screwdriver (see catalogue for various options).
- The product should be sterilized prior to use, as indicated on the label.

**Notes**

- PEEK is a polymer material that is easy to handle in clinical practice.
- PEEK is X-ray opaque. It allows the practitioner to check the fit between the implant and the abutment in X-rays.
- Optimal resin retention is ensured by the shape of the temporary abutments.

## References

Platform	HE		
3.5	Temporary abutment engaging	0144	
	Temporary abutment non-engaging	0142	
	Temporary abutment engaging peek	0826	
	Temporary abutment non-engaging peek	0829	
4.1	Temporary abutment engaging	0015	
	Temporary abutment non-engaging	0007	
	Temporary abutment engaging peek	0827	
	Temporary abutment non-engaging peek	0830	
5.1	Temporary abutment engaging	0145	
	Temporary abutment non-engaging	0143	
	Temporary abutment engaging peek	0828	
	Temporary abutment non-engaging peek	0831	
Platform	HI		
3.5	4.1	Temporary abutment engaging	0491
		Temporary abutment non-engaging	0490
		Temporary abutment engaging peek	0832
		Temporary abutment non-engaging peek	0833
Transepithelial			
		Temporary abutment engaging	0310
		Temporary abutment non-engaging	0309
		Temporary abutment engaging peek	0835
		Temporary abutment non-engaging peek	0834



# 4 Transepithelial abutments

## Description

Our range of transepithelial abutments makes it possible to fabricate a kind of screw-retained restoration on abutments, enabling the restoration connection to be moved to the paragingival level.

Their anti-rotation system enables these abutments to be used in single and multiple restorations.

The various abutment heights and angulations ensure successful solutions for the most difficult cases, especially in multiple immediate restorations (the All-on-4 technique).



## Technical specifications

Connections	platforms			
	HE	3.5	4.1	
HI	3.5	4.1		
Materials	Ti6Al4V – Grade V			
Geometry				

		HE					HI					
		A	B	C	D	E	A	B	C	D	E	
		Straight	Uniblock	3.5	3.5	A/C	4.8	M-1.8x0.35	M-1.4 x 0.3	3.52	A/C	4.8
	Engaging / non engaging	4.1	4.1	A/C	4.8	M-2 x 0.4	M-1.4 x 0.3	3.52	A/C	4.8	M-1.8 x 0.35	M-1.4 x 0.3
	Uniblock	3.5	3.5	A/C	4.8	M-1.8x0.35	M-1.4 x 0.3	3.52	A/C	4.8	M-1.8 x 0.35	M-1.4 x 0.3
	Engaging / non engaging	4.1	4.1	A/C	4.8	M-2 x 0.4	M-1.4 x 0.3	3.52	A/C	4.8	M-1.8 x 0.35	M-1.4 x 0.3

	Angled		HE					HI						
			A	B	C	D	E	F	A	B	C	D	E	F
			17°	3.5	3.5	A/C	4.8	17°	M-1.4 x 0.3	M-1.8x0.35	3.52	A/C	4.8	17°
	4.1	4.1	A/C	4.8	17°	M-1.4 x 0.3	M-2 x 0.4	3.52	A/C	4.8	17°	M-1.4 x 0.3	M-1.8 x 0.35	
	24°	3.5						3.52	A/C	4.8	24°	M-1.4 x 0.3	M-1.8 x 0.35	
		4.1	4.1	A/C	4.8	24°	M-1.4 x 0.3	M-2 x 0.4	3.52	A/C	4.8	24°	M-1.4 x 0.3	M-1.8 x 0.35
	30°	3.5	3.5	A/C	4.8	30°	M-1.4 x 0.3	M-1.8x0.35	3.52	A/C	4.8	30°	M-1.4 x 0.3	M-1.8 x 0.35
		4.1	4.1	A/C	4.8	30°	M-1.4 x 0.3	M-2 x 0.4	3.52	A/C	4.8	30°	M-1.4 x 0.3	M-1.8 x 0.35

A/C = According to catalogue

- ### Usage techniques
- The uniblock straight transepithelial abutments are available in five different heights and are rotated into place, making them simple and easy to fit.
  - The straight and angled two-part transepithelial abutments are available in different heights and with engaging and non-engaging hex.
  - The angulations can be 17° (2, 3 and 4-mm heights), 24° (3 and 4-mm heights), and 30° (3, 4 and 5-mm heights).
  - The AVINENT Implant System includes the entire array of accessories required (castables, temporary abutments, etc.) to fabricate the restorations, as well as healing caps to protect the abutment.
  - The screws for fixing the restoration are 1.4 metric and may be normal hexagonal or slotted-head for cases in which there is a need to reduce the overall height of the restoration.
  - Use the screwdriver ref. 0328 or 0726 for straight abutments and ref. 0804 or 0648 for angled abutments.
  - Restoration screws should be tightened to the transepithelial abutments to a maximum of 20 Ncm.
  - Straight abutments should be tightened to 35 Ncm.
  - Angled abutments should be tightened to 20 Ncm.
  - The product should be sterilized prior to use, as indicated on the label.

- ### Notes
- All the abutments have a click system to ensure ease of handling and positioning in the mouth.
  - The angled abutments include a safety screw that will be used as the permanent screw, and the abutment transporter serves as a reference to verify parallelism.
  - Multiple and single screw-retained restorations can be made.

## References

Platform	HE				Platform	HI	
3.5	Abutment uniblock 1 mm	2464	Angled abutment 17° 2 mm	2467	3.5	Abutment uniblock 1 mm	0765
	Abutment uniblock 2 mm	2465	Angled abutment 17° 3 mm	2468		Abutment uniblock 2 mm	0766
	Abutment uniblock 3 mm	2466				Abutment uniblock 3 mm	0767
			Angled abutment 30° 3 mm	2472		Abutment uniblock 4 mm	0768
	Abutment non-engaging 1 mm	2478				Abutment uniblock 5 mm	0769
	Abutment non-engaging 2 mm	2479					
	Abutment engaging 1 mm	2480				Abutment non-engaging 1 mm	0816
	Abutment engaging 2 mm	2481				Abutment non-engaging 2 mm	0817
						Abutment non-engaging 3 mm	0818
						Abutment non-engaging 4 mm	0819
4.1	Abutment uniblock 1 mm	0190	Angled abutment 17° 2 mm	0257	3.5	Abutment non-engaging 5 mm	0820
	Abutment uniblock 2 mm	0193	Angled abutment 17° 3 mm	0258		Abutment engaging 1 mm	0821
	Abutment uniblock 3 mm	0196	Angled abutment 17° 4 mm	0259		Abutment engaging 2 mm	0822
	Abutment uniblock 4 mm	0199				Abutment engaging 3 mm	0823
	Abutment uniblock 5 mm	0202	Angled abutment 24° 3 mm	0270		Abutment engaging 4 mm	0824
			Angled abutment 24° 4 mm	0271		Abutment engaging 5 mm	0825
	Abutment non-engaging 0.5 mm	0220					
	Abutment non-engaging 1 mm	0222	Angled abutment 30° 3 mm	0764		Angled abutment 17° 3 mm	0808
	Abutment non-engaging 2 mm	0225	Angled abutment 30° 4 mm	0297		Angled abutment 17° 4 mm	0809
	Abutment non-engaging 3 mm	0228	Angled abutment 30° 5 mm	0298			
Abutment non-engaging 4 mm	0231			Angled abutment 24° 3 mm	0810		
Abutment non-engaging 5 mm	0234			Angled abutment 24° 4 mm	0811		
Abutment engaging 0.5 mm	0204			Angled abutment 30° 3 mm	0812		
Abutment engaging 1 mm	0206			Angled abutment 30° 4 mm	0813		
Abutment engaging 2 mm	0209			Angled abutment 30° 5 mm	0814		
Abutment engaging 3 mm	0212						
Abutment engaging 4 mm	0215						
Abutment engaging 5 mm	0218						

Document for internal use of AVINENT Implant System. The range of products may vary in different countries. Please ask your AVINENT dealer for availability.

Document for internal use of AVINENT Implant System. The range of products may vary in different countries. Please ask your AVINENT dealer for availability.

# 5 Impression copings open tray

**Description** This item is used to transfer the position of the implant or abutment to the master mould on which the dental prosthetist will work in the laboratory. It is used in complex jobs to ensure maximum precision.



## Technical specifications

Connections	platforms				
	HE	3.5	4.1	5.1	
HI	3.5	4.1			
Transepithelial					

Materials	Stainless steel 316L
-----------	----------------------

HE

Screw = E

HI

Screw = E

Transepithelial

Screw = E

	HE					II					Transepithelial				
	A	B	C	D	E	A	B	C	D	E	A	B	C	D	E
3.5	3.5	11	4.2	17	M-1.8 x 0.35	3.52	11	4.1	17	M-1.8 x 0.35					
4.1	4.1	11	4.5	15	M-2.0 x 0.40	3.52	11	4.1	17	M-1.8 x 0.35					
5.1	5.1	10	5.5	16	M-2.5 x 0.45										
											4.8	8	5	14	M-1.4 x 0.3

If you work with short screw, D = B

**Usage techniques**

- The engaging impression coping open tray is indicated for single or multiple implant cases, and the non-engaging impression coping open tray is indicated in the case of divergent implants.
- It can be used with the long or short impression screw depending on accessibility in the working area.
- Use with the 0.48-inch screwdriver (see catalogue for various options).
- The product should be sterilized prior to use, as indicated on the label.

**Notes**

- Its shape ensures excellent retention and makes splinting possible.
- The screw head is grooved to improve handling.
- Copings should not be fixed using mechanical means as this may alter the hex.
- The screw is not included (see catalogue for various options).

## References

Platform	HE	
3.5	Open tray engaging	0042
	Open tray non-engaging	0181
	Screw coping open tray S	0046
	Screw coping open tray L	0165
4.1	Open tray engaging	0004
	Open tray non-engaging	0182
	Screw coping open tray S	0019
	Screw coping open tray L	0047
5.1	Open tray engaging	0043
	Open tray non-engaging	0183
	Screw coping open tray S	0048
	Screw coping open tray L	0164
Platform	HI	
3.5 4.1	Open tray engaging	0475
	Open tray engaging (divergent implants)	0874
	Screw coping open tray S	0479
	Screw coping open tray L	0480
Transepithelial		
	Open tray non-engaging	0315
	Open tray engaging	0316

# 6 Impression copings closed tray **AVINENT** Implant System

**Description** This item is used to transfer the position of the implant or abutment to the master mould on which the dental prosthetist will work in the laboratory.



## Technical specifications

Connections	platforms			
	HE	3.5	4.1	5.1
	HI	3.5	4.1	
Transepithelial				

Materials	Stainless steel 316L
-----------	----------------------

Geometry	HE	HI	Transepithelial
	Screw = D	Screw = D	Screw = C

	HE				HI				Transepithelial		
	A	B	C	D	A	B	C	D	A	B	C
3.5	3.5	13	4.3	M-1.8 x 0.35	3.52	13	4.1	M-1.8 x 0.35			
4.1	4.1	13	4.3	M-2.0 x 0.40	3.52	13	4.1	M-1.8 x 0.35			
5.1	5.1	11	5.4	M-2.5 x 0.45							
									4.8	9	M-1.4 x 0.30

**Usage techniques**

- The engaging impression coping closed tray is indicated for single and multiple implant cases, and the non-engaging impression coping closed tray is indicated in the case of multiple implants.
- Impression coping for transepithelial abutment only for multiple implant cases.
- Use the impression coping closed tray ISO 1797 screwdriver (ref. 0723).
- The product should be sterilized prior to use, as indicated on the label.

**Notes**

- External shape facilitates placement.
- Morse taper system on the head of the impression coping for anchoring. This also facilitates the impression by ensuring that the implant-replica assembly is correctly positioned.
- Copings should not be fixed using mechanical means as this may alter the hex.
- Screw included.

## References

Platform	HE	
3.5	Closed tray engaging	0161
	Closed tray non-engaging	0044
4.1	Closed tray engaging	0162
	Closed tray non-engaging	0005
5.1	Closed tray engaging	0163
	Closed tray non-engaging	0045
Platform	HI	
3.5 4.1	Closed tray engaging	0477
	Transepithelial	
	Closed tray non-engaging	0318

# 7 Implant replicas

## Description

This replica of the implant connection or of the transepithelial abutment is fitted once the impression has been made. It enables a master mould with the position of the implants in the mouth to be made and worked on in the laboratory.



## Technical specifications

Connections	platforms					
	HE	3.5	4.1	5.1		
	HI	3.5	4.1			
Transepithelial						

Materials	Stainless steel 316L
-----------	----------------------

HE

6 sides = E

Hexagon height = D  
Internal screw = C

HI

6 sides = E

Hexagon depth = D  
Internal screw = C

Transepithelial

Transepithelial height = D  
Internal screw = C

	HE						HI					Transepithelial				
	A	B	C	D	E		A	B	C	D	E	A	B	C	D	
S	3.5	3.5	9.5	M1.8 x 0.35	0.7	2.4										
	4.1	4.1	9.5	M2.0 x 0.40	0.7	2.7										
	5.1	5.1	9.5	M2.5 x 0.45	0.7	3.4										
L	3.5	3.5	12	M1.8 x 0.35	0.7	2.4	3.5	12	M1.8 x 0.35	2	2.42					
	4.1	4.1	12	M2.0 x 0.40	0.7	2.7	4.1	12	M1.8 x 0.35	2	2.42					
	5.1	5.1	12	M2.5 x 0.45	0.7	3.4										
												4.8	10	M1.4 x 0.3	2.15	

**Usage techniques** - The positioning of the replica and impression coping should always be checked.

## Notes

- It is possible to work with two lengths: 9.5 mm and 12 mm.
- The first reference mark at 2.5 mm down the replica head ensures that the silicone that reproduces the artificial gum is uniform in volume. It also serves as a marker and anchoring point when it comes to repositioning it on the mould.
- The second reference mark indicates the maximum limit for filling the gingival mask.
- Its shape guarantees excellent retention in the plaster.
- Abutments should not be fixed using mechanical means as this may alter the hex.
- Available in ten-unit packs.

## References

Platform	HE	
3.5	Implant replica S	0053
	Implant replica L	0051
4.1	Implant replica S	0017
	Implant replica L	0013
5.1	Implant replica S	0054
	Implant replica L	0052
Platform	HI	
3.5	Implant replica	0581
	Implant replica	0585
Transepithelial		
Implant replica		0322

## 8 Overdentures

---

**Description**

Overdentures are restorations that the patient can place and remove.

These prostheses supported on the mucous membranes are fixed to the dental implants by means of an auxiliary anchoring system.

We have two systems for fabricating this kind of restoration, the Swiss Dalbo®-System and the Locator® Implant Attachment System.

The specifications of these systems are detailed in sections 8A and 8B.

---

## Description

This ball-anchor system is indicated for fabricating overdentures that place on implants. The system consists of two parts: a male part screwed to the implant (ball abutment) and a female part fixed to the restoration by means of acrylic resins. There are three different types within the Dalbo® system: the Dalbo® Classic, the Dalbo® Classic elliptic (better retention of the restoration in the resin) and the Dalbo® Plus (grade-4 titanium, which is less prone to wear).



## Technical specifications

Connections	platforms
	HE 4.1
Materials	Ti6Al4V – Grade V
Geometry	

HE								
	A	B	C	D	E	F	G	H
4.1	4.1	2.95	A/C	4.48	3.45	M2.0 x 0.40	2.25	2.4

A/C = According to catalogue

- ### Usage techniques
- The ball abutment should be screwed to 20 Ncm.
  - For correct placement, the Dalbo® ISO 1797 screwdriver (ref. 0722) is required. The Dalbo® impression coping and replica are also needed to fabricate the restoration.
  - The system of lamellae that enables the restoration to be retained is activated by the Dalbo® activator/deactivator, which is necessary to safeguard the system and prevent damage to it.
  - The product should be sterilized prior to use, as indicated on the label.

- ### Notes
- Before employing the system, you should read the instructions.
  - The titanium ball abutment is 2.5 mm in diameter.
  - The flexible lamellae of the female part can be activated/deactivated to achieve greater or lesser retention of the restoration.

## References

Platform	HE						
4.1	<table border="1"> <tr> <td>Abutment ball attachment HE 4.1 x 2 mm</td> <td>0107</td> </tr> <tr> <td>Abutment ball attachment HE 4.1 x 4 mm</td> <td>0108</td> </tr> <tr> <td>Abutment ball attachment HE 4.1 x 6 mm</td> <td>0109</td> </tr> </table>	Abutment ball attachment HE 4.1 x 2 mm	0107	Abutment ball attachment HE 4.1 x 4 mm	0108	Abutment ball attachment HE 4.1 x 6 mm	0109
Abutment ball attachment HE 4.1 x 2 mm	0107						
Abutment ball attachment HE 4.1 x 4 mm	0108						
Abutment ball attachment HE 4.1 x 6 mm	0109						

Accessories	
Screwdriver Dalbo® (ISO 1797)	0722
Ball attachment replica	0761
Smart transfer Dalbo® adjustable	0762

Accessories Dalbo® Classic	
Female part E	0152
Female part elliptic	0153
Spacer	0154
Activator	0155
Deactivator	0156

Accessories Dalbo® Plus	
Female part TE	0157
Spacer	0158
Activator / deactivator	0159

### Description

The Locator® system is indicated for fabricating overdentures that fit on implants. The low-profile supragingival anchor consists of two parts: the Locator® Abutment, which is screwed to the implant, and the metal cap with a nylon button that is placed in the restoration.



### Technical specifications

Connections	platforms			
	HE	3.5	4.1	5.1
HI	3.5	4.1		

Screw = F

Screw = F

Locator Abutment + Female (section)

	HE						HI					
	A	B	C	D	E	F	A	B	C	D	E	F
3.5	3.5	1.45	A/C	3.86	2.45	M-1.8 x 0.35	3.45	1.45	A/C	3.86	2.45	M-1.8 x 0.35
4.1	4.1	1.45	A/C	3.86	2.45	M-2.0 x 0.4	3.45	1.45	A/C	3.86	2.45	M-1.8 x 0.35
5.1	5.1	1.45	A/C	3.86	2.45	M-2.5 x 0.45						

A/C = According to catalogue

- ### Usage techniques
- The Locator® abutment should be screwed to 20 Ncm using the 0.48-inch screwdriver attached to the main tool of the Locator® system.
  - The main Locator® tool is required for correct positioning.
  - The restoration can be made directly in the mouth or in the laboratory. If it is fabricated in the laboratory, it is made directly on the implant or with the Locator® replica and impression coping.
  - The product should be sterilized prior to use, as indicated on the label.

### Notes

- Before using the system, you should read the instructions.
- The total height of the anchor (abutment+male) on HE and HI implants is just 2.45 mm.
- Total divergence between implants of up to 40° is possible.
- Excellent ability to withstand wear (60,000 cycles per 230 g).
- Self-alignment function to make handling easier for patients.

### References

Platform	HE	
3.5	Locator® abutment HE 3.5 x 1 mm	2458
	Locator® abutment HE 3.5 x 2 mm	2459
	Locator® abutment HE 3.5 x 3 mm	2460
	Locator® abutment HE 3.5 x 4 mm	2461
	Locator® abutment HE 3.5 x 5 mm	2462
4.1	Locator® abutment HE 4.1 x 0.73 mm	0352
	Locator® abutment HE 4.1 x 2 mm	0353
	Locator® abutment HE 4.1 x 3 mm	0354
	Locator® abutment HE 4.1 x 4 mm	0355
	Locator® abutment HE 4.1 x 5 mm	0356
	Locator® abutment HE 4.1 x 6 mm	0357
5.1	Locator® abutment HE 5.1 x 1 mm	0358
	Locator® abutment HE 5.1 x 2 mm	0359
	Locator® abutment HE 5.1 x 3 mm	0360
	Locator® abutment HE 5.1 x 4 mm	0361
	Locator® abutment HE 5.1 x 5 mm	0362
Platform	HI	
3.5	Locator® abutment HI 0	0596
	Locator® abutment HI 1	0597
	Locator® abutment HI 2	0598
	Locator® abutment HI 3	0599
	Locator® abutment HI 4	0600
	Locator® abutment HI 5	0601

Accessories	
Processing cap	0368
Locator® core tool	0371
Impression coping	0369
Female analogue	0370
Replacement male white	0363
Light retention replacement male pink	0364
Extra light retention replacement male blue	0365
Extended range replacement male green	0366
Extended range extra replacement male red	0367

## 9 Cemented restorations

### Description

Cemented restorations are restorations that are fixed in the patient's mouth and which are attached to the implant by means of cement. Machined abutments are used for cemented restorations and any of those listed in the AVINENT Implant System may be employed.

Each abutment is placed taking into consideration the angle of insertion of the restoration. Divergences between implants can be corrected, if they are not too great, by means of angled abutments.

AVINENT supplies straight abutments and abutments in a range of angulations with varying characteristics suitable for use with either internal or external hex. The specifications of these abutments is detailed in section 9A.



# 9A Abutment for cemented restoration

**Description** Any of the AVINENT Implant System machined abutments can be used for this kind of restoration.  
The abutments are screwed to the implant and a restoration is fabricated. This restoration is cemented to the abutment in the usual manner.



## Technical specifications

Connections	platforms				
	HE	3.5	4.1	5.1	
HI	3.5	4.1			

Materials	Ti6Al4V – Grade V
-----------	-------------------

Cemented Abutments HE

Cemented Abutments HI

	HE					HI					
	A	B	C	D	E	A	B	C	D	E	
Straight abutment	3.5	3.5	8	1	4.5		3.52	8	A/C	4.5/5.5/6.5	
	4.1	4.1	8	A/C	5.5		3.52	8	A/C	4.5/5.5/6.5	
	5.1	5.1	8	1	6.5						
Angled abutment	3.5	3.5	8	1	4.5	17°	3.52	8	A/C	4.5/5.5/6.5	17°
	4.1	4.1	8	A/C	5.5	17°	3.52	8	A/C	4.5/5.5/6.5	17°
	5.1	5.1	8	1	6.5	17°					

A/C = According to catalogue

**Usage techniques**

- Machined straight and 17° angled abutments are available for HE and HI.
- They should be tightened using a torque wrench to 35 Ncm.
- Use the 0.48-inch screwdriver (see catalogue for various options).
- The product should be sterilized prior to use, as indicated on the label.

**Notes**

- HE abutments have a hex consisting of two hexagons (a dodecagon) that increases the possibilities for placing the abutment by giving the best insertion axis for the subsequent fabrication of the restoration.
- Abutments of different heights, from 1 to 5 mm, suitable for every situation are available.
- Abutments are made of material that can be cut to shape.
- The straight abutments have a shape with palatal-lingual function. They also have an anti-rotation plane for positioning single crowns.

## References

Platform	HE	
3.5	Straight abutment HE 4.5 x 1 mm (3.5)	1710
	Angled abutment HE 17° 4.5 x 1 mm (3.5)	1718
4.1	Straight abutment HE 5.5 x 1 mm (4.1)	1714
	Straight abutment HE 5.5 x 3 mm (4.1)	1715
	Angled abutment HE 17° 5.5 x 1 mm (4.1)	1720
5.1	Angled abutment HE 17° 5.5 x 3 mm (4.1)	1721
	Straight abutment HE 6.5 x 1 mm (5.1)	1716
	Angled abutment HE 17° 6.5 x 1 mm (5.1)	1722
	Platform	HI
3.5 4.1	Straight abutment HI 4.5 x 1 mm	1724
	Straight abutment HI 4.5 x 3 mm	1725
	Straight abutment HI 5.5 x 1 mm	1726
	Straight abutment HI 5.5 x 3 mm	1727
	Straight abutment HI 5.5 x 5 mm	1728
	Straight abutment HI 6.5 x 3 mm	1729
	Angled abutment HI 17° 4.5 x 1 mm	1730
	Angled abutment HI 17° 4.5 x 3 mm	1731
	Angled abutment HI 17° 5.5 x 1 mm	1732
	Angled abutment HI 17° 5.5 x 3 mm	1733
Angled abutment HI 17° 5.5 x 5 mm	1734	
Angled abutment HI 17° 6.5 x 3 mm	1735	

## Description

Screw-retained restorations are restorations that are fixed in the patient's mouth screwed into the implants or transepithelial abutments. They cannot be removed by the patient.

They may be single, multiple or entire restorations and may be made of a range of materials such as zirconium, ceramic and metal, and acrylic resins.

This technique can be used to obtain prosthetic restorations made of zirconium (see section 10A) or of various conventional alloys (see section 10B).

The AVINENT Implant System features a full range of fixing screws for every situation.

**Permanent abutment screw:** Grade-5 titanium screw with outstanding mechanical properties and ability to withstand fracture that is placed permanently in the mouth. The abutment should be screwed to the implant to 35 Ncm and onto the transepithelial abutment to 20 Ncm using the 0.48-inch screwdriver.

**Lab screw:** Grade-5 titanium screw in blue, used in the process to fabricate the restoration in the laboratory, as it aids the work of the technician due the fact that it has fewer thread pitches and can be reused. It is also suitable for use in the various trial fits on patients. When the restoration is permanently fitted, new screws must always be used to guarantee unimpaired mechanical properties. It should be screwed to 35 Ncm using the 0.48-inch screwdriver.

**Small-headed screw:** Grade-5 titanium steel with head 1.5 mm smaller than the standard screws. This screw provides an excellent solution in cases in which the restoration space is very small or where the height of the screw head is a hindrance when it comes to achieving a greater angling of the structures. It should be screwed to 35 Ncm using the 0.48-inch screwdriver.

**Gold screw:** Identical in shape to the abutment screw but approximately 60% gold in composition.

Square-headed to increase ability to withstand torsion.

It should be screwed to 35 Ncm using the screwdriver for gold screws.

Ten-unit bags are available for some types of screws.

Screws are included with some products (straight and angled abutments, aesthetic abutments, transepithelial abutments and titanium bases).

# 10A-1 Screw-retained restoration Coping for zirconium

## Description

This metal item serves as a support for modelling in resin the part or structure that will be replicated in zirconium using a manual milling unit.



## Technical specifications

Connections	platforms		
	HE	3.5	4.1
HI	3.5	4.1	
Transepithelial			

Materials
Ti6Al4V – Grade V

HE

HI

Transepithelial

	HE			HI			Transepithelial		
	A	B	C	A	B	C	A	B	C
3.5	3.6	10	1	3.52	10.2	1.20			
4.1	4.2	10	1	3.52	10.2	1.20			
5.1	5.2	10	1						
							4.9	10	1

## Usage techniques

- Use the appropriate coping and screw to suit the implant hex and platform.
- Only available in rotating format for making multiple restorations on implants.
- It should be screwed to 35 Ncm using the 0.48-inch screwdriver.

## Notes

- Its external shape ensures excellent retention of the resin.
- It is made of thin-section material that can easily be cut.
- The larger diameter of the external measurements of the coping enables the join between the implant and the accessory to be reworked following the sintering of the zirconium.
- The increased thickness of the titanium at the screw emplacement prevents any possible fracturing of the zirconium once sintered.
- Copings can be reused.

## References

Platform	HE
3.5	Coping for zirconia non-engaging   0285
4.1	Coping for zirconia non-engaging   0286
5.1	Coping for zirconia non-engaging   0287
Platform	HI
3.5   4.1	Coping for zirconia non-engaging   0649
Transepithelial	
	Coping for zirconia non-engaging   0558
	Coping for zirconia engaging   0559

# 10A-2 Screw-retained restoration Coping titanium base

## Description

This metal item serves as a support for modelling in resin the part or structure that will be replicated in zirconium and which will be used on a titanium base for single and multiple restorations.



## Technical specifications

Connections	platforms			
	HE		4.1	
HI	3.5	4.1		

Materials	Ti6Al4V – Grade V
-----------	-------------------

Coping for zirconia (Ti base) HE

Coping for zirconia (Ti base) HI

	HE				HI			
	A	B	C	D	A	B	C	D
3.5					3.52	A/C	A/C	4.9
4.1	4.1	A/C	A/C	4.9	3.52	A/C	A/C	4.9

A/C = According to catalogue

## Usage techniques

- To fabricate these restorations, bases will be put in place and copings will be used in the same way as for a conventional structure (see section 10A1).
- Use the appropriate coping, base and screw to suit the implant hex and platform.
- Different bases are available for every gum height, from 0.5 to 5 mm in HE and from 1 to 5 mm in HI. Hexagonal and cylindrical bases for single and multiple pieces are also available.
- The base should always be employed with its screw to 35 Ncm and used with the 0.48-inch screwdriver.
- The permanent screw is seated in the zirconium and not the titanium base. For handling it during modelling and final placement.

## Notes

- Metal bases should be used with all zirconium prosthetics, mostly in single restorations, to prevent possible damage to the implant head caused by the hardness of the zirconium on the titanium.
- The external shape of the coping guarantees excellent retention of the resin.
- It is made of thin-section material that can easily be cut.
- The external measurements of the coping make it possible to employ a larger diameter, enabling the join between the implant and the accessory to be reworked following the sintering of the zirconium.
- The increased thickness of the titanium at the screw emplacement prevents any possible fracturing of the zirconium once sintered.
- The copings can be reused.
- The shape of the upper part of the machined base allows it to be fixed to the coping, thereby enabling it to be correctly positioned and preventing the parts from rotating.

## References

Coping for zirconia engaging On titanium bases	0492
--	------

Platform	HE	
4.1	Titanium base for zirconia engaging 4.1 x 0.5 mm	0531
	Titanium base for zirconia engaging 4.1 x 1 mm	0532
	Titanium base for zirconia engaging 4.1 x 2 mm	0533
	Titanium base for zirconia engaging 4.1 x 3 mm	0534
	Titanium base for zirconia engaging 4.1 x 4 mm	0535
	Titanium base for zirconia engaging 4.1 x 5 mm	0536
	Titanium base for zirconia non-engaging 4.1 x 0.5 mm	0973
	Titanium base for zirconia non-engaging 4.1 x 1 mm	0974
	Titanium base for zirconia non-engaging 4.1 x 2 mm	0975
	Titanium base for zirconia non-engaging 4.1 x 3 mm	0976
Titanium base for zirconia non-engaging 4.1 x 4 mm	0977	
Titanium base for zirconia non-engaging 4.1 x 5 mm	0978	
Platform	HI	
4.1	Titanium base for zirconia engaging 4.1 x 1 mm	0748
	Titanium base for zirconia engaging 4.1 x 2 mm	0749
	Titanium base for zirconia engaging 4.1 x 3 mm	0750
	Titanium base for zirconia engaging 4.1 x 4 mm	0751
	Titanium base for zirconia engaging 4.1 x 5 mm	0752
	Titanium base for zirconia non-engaging 4.1 x 1 mm	0979
	Titanium base for zirconia non-engaging 4.1 x 2 mm	0980
	Titanium base for zirconia non-engaging 4.1 x 3 mm	0981
	Titanium base for zirconia non-engaging 4.1 x 4 mm	0982
	Titanium base for zirconia non-engaging 4.1 x 5 mm	0983

# 10B-1 Screw-retained restoration Castable abutment

**Description** This polymer cylinder is used as a support for modelling in resin single or multiple restorations. It preserves the dimensions of the hex for subsequent casting in the lost-wax mould.



## Technical specifications

Connections	platforms		
	HE	3.5	4.1
HI	3.5	4.1	
Transepithelial			

**Materials** POM H (polyoxymethylene homopolymer)

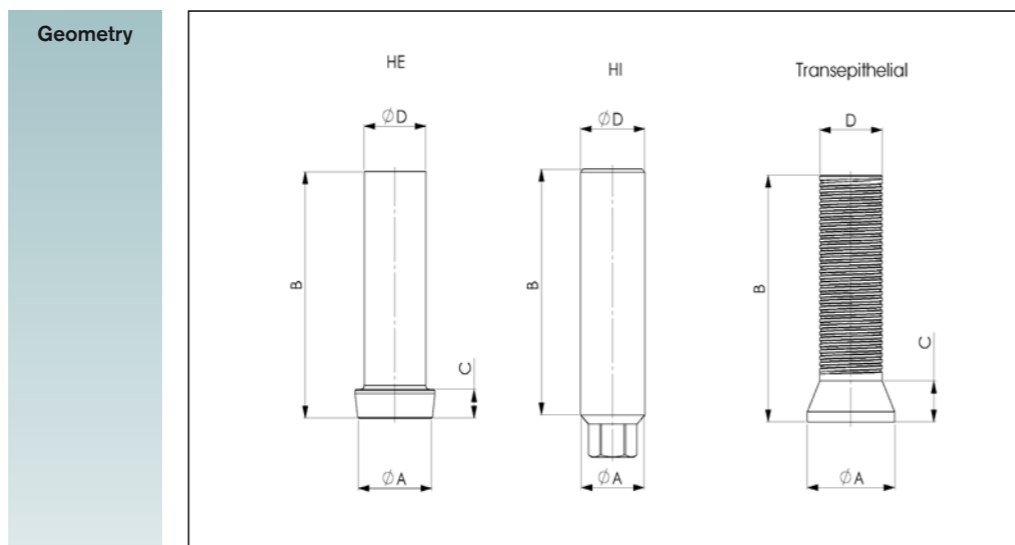

	HE				HI				Transepithelial			
	A	B	C	D	A	B	C	D	A	B	C	D
3.5	3.5	12	1.4	3.45	3.52	12		3.6				
4.1	4.1	12	1.4	3.45	3.52	12		3.6				
5.1	5.1	12	1.60	4								
									4.9	10	1	3

A/C = According to catalogue

- Usage techniques**
- Use the appropriate castable abutments to suit the implant hex and platform to fabricate the structure out of wax or acrylic resin, which is then transformed into metal cast using the lost-wax technique.
  - For correct usage of these techniques and to ensure optimal results and the final quality of the castable, the instructions given by the companies that supply the coatings and metals should be followed.
  - Once the restoration is complete, and in accordance with the material used, the optimal final finish and hex fitting are achieved by means of a glass bead spray.
  - Once the metal structure has been made, it is then loaded with the ceramic.

- Notes**
- The external part of the castables features retentions that allow mechanical fixing of the elements used to model the structures, be they wax or acrylic resins.
  - Rotating castables have an angulation of 3° inside the connection to the implant, making it easier to position the restoration by allowing a degree of divergence between the implants.
  - Available in ten-unit packs.

## References

Platform	HE	
3.5	Castable cylinder non-engaging	0055
	Castable cylinder engaging	0057
4.1	Castable cylinder non-engaging	0006
	Castable cylinder engaging	0014
5.1	Castable cylinder non-engaging	0056
	Castable cylinder engaging	0058
Platform	HI	
3.5	Castable cylinder non-engaging	0589
4.1	Castable cylinder engaging	0591
	Transepithelial	
	Castable cylinder non-engaging	0307
	Castable cylinder engaging	0308

# 10B-2 Screw-retained restoration Castable abutment titanium base

AVINENT®  
Implant System

**Description** This polymer cylinder is used as a support for modelling pieces in resin and is used on a machined titanium base for single and multiple restorations.



## Technical specifications

Connections	platforms		
	HE	4.1	
HI	3.5	4.1	

Materials	POM H (polyoxymethylene homopolymer)	Ti6Al4V - Grade V
-----------	--------------------------------------	-------------------

Castable cylinder (Ti base) HE

Castable cylinder (Ti base) HI

	HE				HI			
	A	B	C	D	A	B	C	D
3.5					3.52	A/C	A/C	4.9
4.1	4.1	A/C	A/C	4.8	3.52	A/C	A/C	4.9

A/C = According to catalogue

Document for internal use of AVINENT Implant System  
The range of products may vary in different countries. Please ask your AVINENT dealer for availability

**Usage techniques**

- To fabricate these restorations, bases will be put in place and castables will be used in the same way as for a conventional structure (see section 10B1).
- The appropriate castable, base and screw are used to suit the implant hex and platform.
- Different bases are available for every gum height, from 0.5 to 5 mm in HE and from 1 to 5 mm in HI. Hexagonal and cylindrical bases for single and multiple pieces are also available.
- The base should always be employed with its screw to 35 Ncm and used with the 0.48-inch screwdriver.
- The permanent screw is seated in the metal and not the titanium base. For handling it during modelling and trial fits on the patient, cyanoacrylate can be used.

**Notes**

- The castables in this system have the same characteristics as the normal ones but have a shape that is adaptable to fit the titanium bases (see section 10B1).
- The shape of the upper part of the machined base allows it to be fixed to the castable, thereby enabling it to be correctly positioned and preventing the different parts from rotating.

## References

Platform	Castable cylinder engaging. On titanium bases	0493
Platform	HE	
4.1	Titanium base for zirconia engaging 4.1 x 0.5 mm	0531
	Titanium base for zirconia engaging 4.1 x 1 mm	0532
	Titanium base for zirconia engaging 4.1 x 2 mm	0533
	Titanium base for zirconia engaging 4.1 x 3 mm	0534
	Titanium base for zirconia engaging 4.1 x 4 mm	0535
	Titanium base for zirconia engaging 4.1 x 5 mm	0536
	Titanium base for zirconia non-engaging 4.1 x 0.5 mm	0973
	Titanium base for zirconia non-engaging 4.1 x 1 mm	0974
	Titanium base for zirconia non-engaging 4.1 x 2 mm	0975
	Titanium base for zirconia non-engaging 4.1 x 3 mm	0976
	Titanium base for zirconia non-engaging 4.1 x 4 mm	0977
Titanium base for zirconia non-engaging 4.1 x 5 mm	0978	
Platform	HI	
3.5 4.1	Titanium base for zirconia engaging 4.1 x 1 mm	0748
	Titanium base for zirconia engaging 4.1 x 2 mm	0749
	Titanium base for zirconia engaging 4.1 x 3 mm	0750
	Titanium base for zirconia engaging 4.1 x 4 mm	0751
	Titanium base for zirconia engaging 4.1 x 5 mm	0752
	Titanium base for zirconia non-engaging 4.1 x 1 mm	0979
	Titanium base for zirconia non-engaging 4.1 x 2 mm	0980
	Titanium base for zirconia non-engaging 4.1 x 3 mm	0981
	Titanium base for zirconia non-engaging 4.1 x 4 mm	0982
	Titanium base for zirconia non-engaging 4.1 x 5 mm	0983

Document for internal use of AVINENT Implant System  
The range of products may vary in different countries. Please ask your AVINENT dealer for availability

# 10B-3 Screw-retained restoration Gold castable

## Description

This polymer cylinder with machined gold base serves as a support for modelling single and multiple pieces. It preserves the dimensions of the hex for subsequent casting, ensuring greater accuracy thanks to its metal base.



## Technical specifications

Connections	platforms		
	HE	3.5	4.1
HI	3.5	4.1	

Materials	Gold (composition: Au 60%, PT 19% and Ir 1%)	POM H (polyoxymethylene homopolymer)
-----------	--	--------------------------------------

Gold castable cylinder HE

Gold castable cylinder HI

	HE				HI			
	A	B	C	D	A	B	C	D
3.5	3.5	12.3	1.9	4.2	3.52	11.40	1	4.2
4.1	4.1	12.3	1.9	4.2	3.52	11.40	1	4.2
5.1	5.1	12.3	1.9	4.2				

- ## Usage techniques
- The appropriate gold castable is chosen to suit the implant and hex, and the structure is fabricated using wax or acrylic resin, which is then turned into metal cast using the burn-out technique.
  - For correct usage of these techniques and to ensure optimal results and the final quality of the gold castable, follow the instructions given by the companies that supply the coatings and metals.
  - Bear in mind the specific characteristics of the noble metal to ensure the gold base and the casted metal are properly joined.
  - Once the metal structure has been made, it is then loaded with the ceramic.

## Notes

- The metal base allows screw-retained restorations to be fabricated with a fit between the structure and the implant like that achieved with a machined piece.
- The base and the casted metal are connected by means of a mechanical retention.

## References

Platform	HE		
3.5	Gold castable cylinder non-engaging	0110	
	Gold castable cylinder engaging	0113	
4.1	Gold castable cylinder non-engaging	0111	
	Gold castable cylinder engaging	0114	
5.1	Gold castable cylinder non-engaging	0112	
	Gold castable cylinder engaging	0115	
Platform	HI		
3.5	4.1	Gold castable cylinder non-engaging	0654
		Gold castable cylinder engaging	0606







**AVINENT**<sup>®</sup>  
Implant System

Pol. Industrial Santa Anna I · Apartado 20  
08251 Santpedor (Barcelona) · España  
T. (+34) 902 38 38 48 · F. (+34) 93 827 38 73  
[www.avinent.com](http://www.avinent.com) [avinent@avinent.com](mailto:avinent@avinent.com)